

HHM100/I
HHL100/I/PH



BT High Lifters allow ergonomic handling of goods. The ergonomical working height — fully adjustable — is ideal for distribution and sorting operations. Maximum lift capacity 1000kg, maximum lift height 810mm. Short truck length provides narrow turning radius.



Technical Details		HHM100/ HHM100I	HHL100/ HHL100I	HHL100PH
Power unit		—	Battery	Battery
Rated capacity	kg	1000	1000	1000
Weight without battery	kg	121	135	135
Steer wheels, polyurethane	mm	Ø 175x60	Ø 175x60	Ø 175x60
Fork wheels, nylon	mm	Ø 75x75	Ø 75x75	Ø 75x75
Lifting time fork, without/with rated load	s	—	11/19	11/19
Lifting height per pump stroke, without/with rated load	mm	32/13	—	—
No. of pump strokes to full elevated fork, without/with rated load		28/65	—	—

Dimensions, mm		HHM100/ HHM100I	HHL100/ HHL100I	HHL100PH
x	Front axle to fork face	980	980	980
y	Wheel base, fork raised/lowered	990/1280	990/1280	990/1280
h ₁₃	Height of lowered fork	88	88	88
l ₂	Truck length incl. back of fork	455	455	455
b ₁	Chassis, width	560	560	560
s	Fork thickness	50	50	50
e	Fork width	160	160	160
l	Fork length	1190	1190	1190
b ₅	Width across fork	560	560	560
m ₂	Floor clearance mid wheelbase	20	20	20
A _{st}	Aisle width, min Pallet 800x1200 mm	1855	1855	1855
W _a	Turning radius	1487	1487	1487
h ₃	Lift height	810	810	810
h ₆	Height of truck	930	930	930
h ₁₄	Height of handle in neutral pos.	1280	1280	1280

Battery and charger		HHL100/HHL100I/HHL100PH	
Battery capacity	Ah	51	
Battery charger	A	6	
Voltage	V	12	
Battery weight	kg	18	

Truck performance and dimensions are nominal and subject to tolerances.
BT Products AB products and specifications are subject to change without notice.
VAll data is based on VDI 2198.

High Lifter

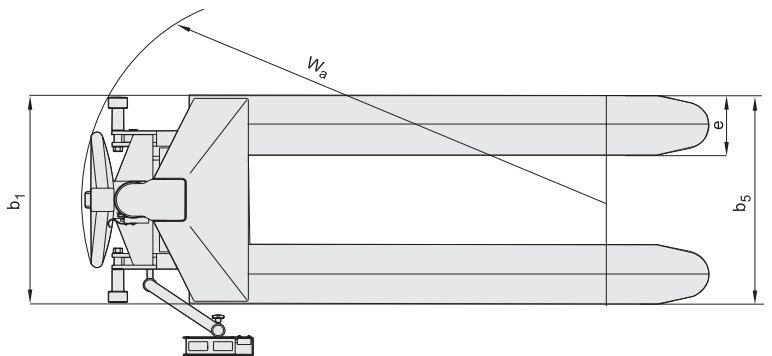
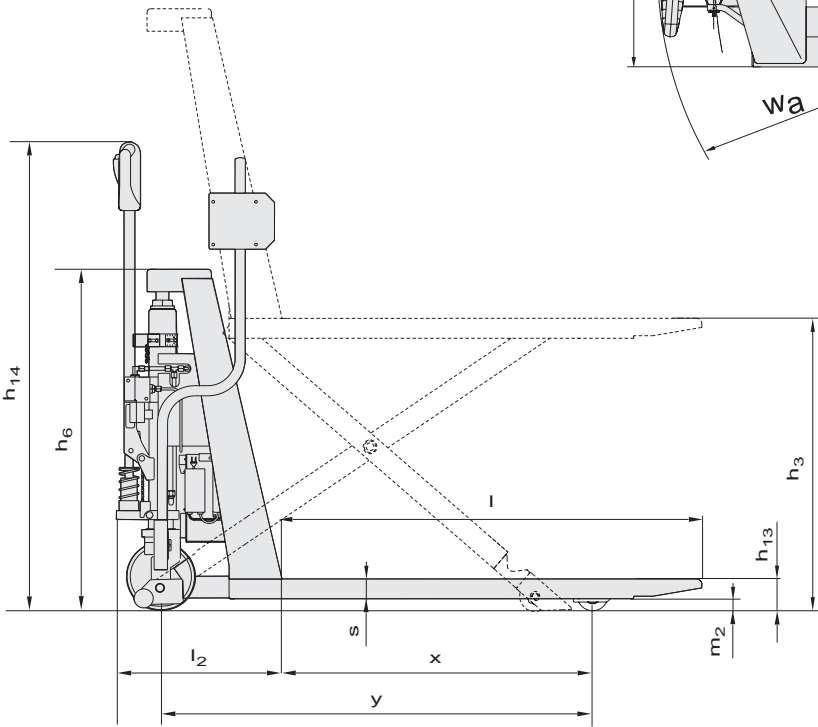
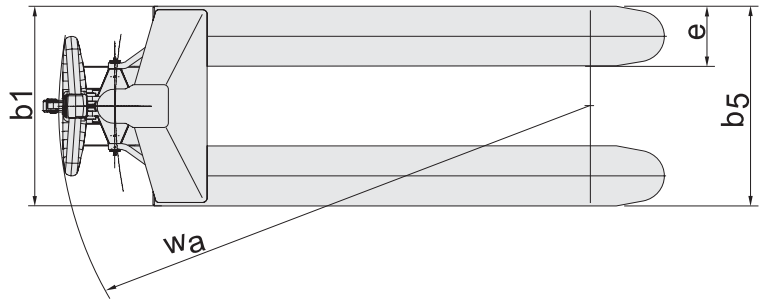
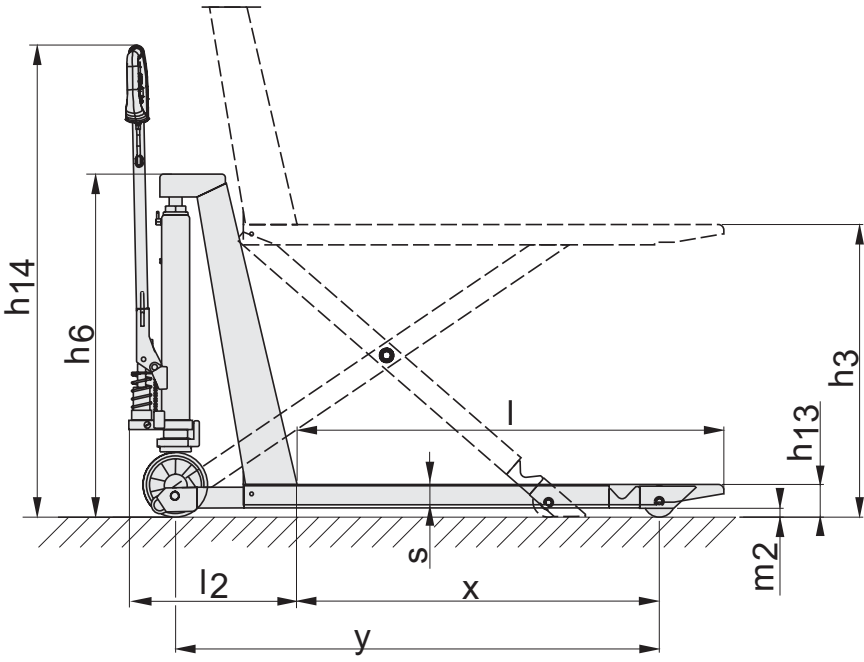



- Supporting clamps in front of the rollers reduce the risk of tipping forward.
- Adjustable stabilizers automatically brake, to ensure safety and stability in operation.

HHM100 — Manual

- QUICKLIFT-function as standard with automatic transfer to normal lift with loads over 250kg
- This product has been environmentally declared. Separate information sheet is available.

HHL100 — Electric

- Decreases risk of tilting due to placement of the motor / battery between the cylinder and A-frame.
- Can be pumped manually when the battery is discharged.
- Maintenance free battery and secure battery compartment.
- Integrated battery charger with LED indicator. Separate charging cable.
- Emergency cut-off, which can be used as a key.
- This product has been environmentally declared. Separate information sheet is available.

HHL100PH — with photocell

- The photocell gives a smooth and controlled movement as the High Lifter lowers and raises automatically when goods are loaded or unloaded from the pallet. This gives you an ergonomic working level.
- Maximum working height for the photocell is 1150 mm.

HHM100I/HHL100I — INOX

- Frame, tow bar, axles and fork wheel bearings in stainless steel gives reliability and a long life to the truck. Other components are gavanized and painted.
- Glass blasted smooth surfaces ensures easy cleaning.

Truck features	HHM100/I	HHL100/I	HHL100PH
Choice of chassis widths	S	S	S
Choice of wheel types	—	—	—
Choice of fork lengths	O	O	O
Quick-lift version	S	—	—
Controls and instruments			
Tiller arm steering	S	S	S
Driving features			
180° steering	S	S	S
Safety features			
Automatic stabilisers	S	S	S
Emergency cut-off	—	S	S
Handbrake	O/—	O/—	O
Parking brake	O/—	O/—	O
Maintenance features			
Lubrication points	S	S	S
Battery management features			
Battery status indicator	—	S	S
Built-in charger	—	S	S

S = Standard feature

O = Optional feature

— = Not available