



## Pedestrian Pallet Truck walkie application — medium duty

The ORION Range with modern styling is ideally suited for walkie applications regarding loading / unloading and horizontal pallet movement. LWE180 is a strong and robust truck that can travel 6km/h with/without load. Narrow chassis with castor wheels fully rotating within the chassis profile.

- The **comfortable steering arm**, with its modern design, facilitates one hand operation — either left or right hand. The display on the handle gives useful information.
- The **BT Castorlink system** ensures superb stability and secure driving due to connected, spring mounted castor wheels together with a fixed drive wheel.
- The **BT POWERDRIVE system**. The unique integration of contactless controls, CAN-Bus communication and a separately excited drivemotor gives many advantages. The contactless controls give smooth and effortless driving. The CAN-Bus communication provides quick, reliable transmission and only a few communication cables are needed. The separately excited drivemotor allows easy programming of its performance — top speed, acceleration and automatic speed reduction — to suit the application.
- Choice of having **PIN Code** (up to 100) instead of key. Provides access control. Each code can store individual parameters to meet the driver's skill / environment.
- **CLICK-2-CREEP**. Drive mode for safe manoeuvring in very tight situations.
- **Regenerative braking**, energy back to the battery.
- Sufficient battery capacities — two different **battery compartments** — for operation during a working shift.



Technical Details		LWE180
Rated capacity	kg	1800
Load centre	mm	600
Weight without battery	kg	310
Max. axle load drive wheel, without/with rated load	kg	275/680
Max. axle load castor wheels, without/with rated load	kg	2x752x75
Max. axle load fork wheels, without/with rated load	kg	45+45/740+740
Castor wheels, polyurethane	mm	Ø 125x40
Fork wheels, single or bogie, Vulkollan	mm	Ø 85
Drive wheel, Vulkollan	mm	Ø 215x70
Travel speed, without/with rated load	km/h	6/6
Lift speed, without/with rated load	m/s	0.05/0.04
Lowering speed, without/with rated load	m/s	0.05/0.04
Gradient, without/with rated load	%	18/9
Service-/parking brake		electromagnetic brake
Drive motor/Intermittent rating	kW/%	1.0/60
Lift motor/Intermittent rating	kW/%	1.2/10
Steering system		steering arm
Speed control, number of steps		transistor, stepless
Steering arc	°	200

Dimensions, mm		LWE180
x	Back of fork to bogie wheel centre (l=1150 mm, fork raised)	924
h <sub>23</sub>	Total lift height	205
h <sub>14</sub>	Height of handle in neutral pos.	1270
h <sub>13</sub>	Height of lowered fork	85
b <sub>1</sub>	Chassis, width	726
e	Fork width	156
l	Fork length	810/910/965/1000/1120/1150/1200/1370/ 1450/1520
b <sub>5</sub>	Width across fork	450/520/536/550/685
m <sub>1</sub>	Floor clearance	40

Data is based on standard battery compartment, medium size, l=1150mm

Dimensions — Standard battery compartment		Small battery compartment	Medium battery compartment	
y	Wheel base, fork raised/lowered (l=1150)	mm	1274/1334	1320/1380
l <sub>2</sub>	Truck length incl. back of fork	mm	519	565
A <sub>st</sub>	Aisle width, min (Pallet 800x1200 mm)	mm	1919	1965
W <sub>a</sub>	Turning radius, fork raised	mm	1443	1489
	Battery capacity, min./max.	Ah	120/160	180/240
	Voltage	V	24	24
	Battery weight, min./max.	kg	120/165	150/210

Performance may vary due to motor and system efficiency tolerance and represents nominal values obtained under typical operating conditions.

BT Products AB products and specifications are subject to change without notice.

All data is based on VDI 2198.

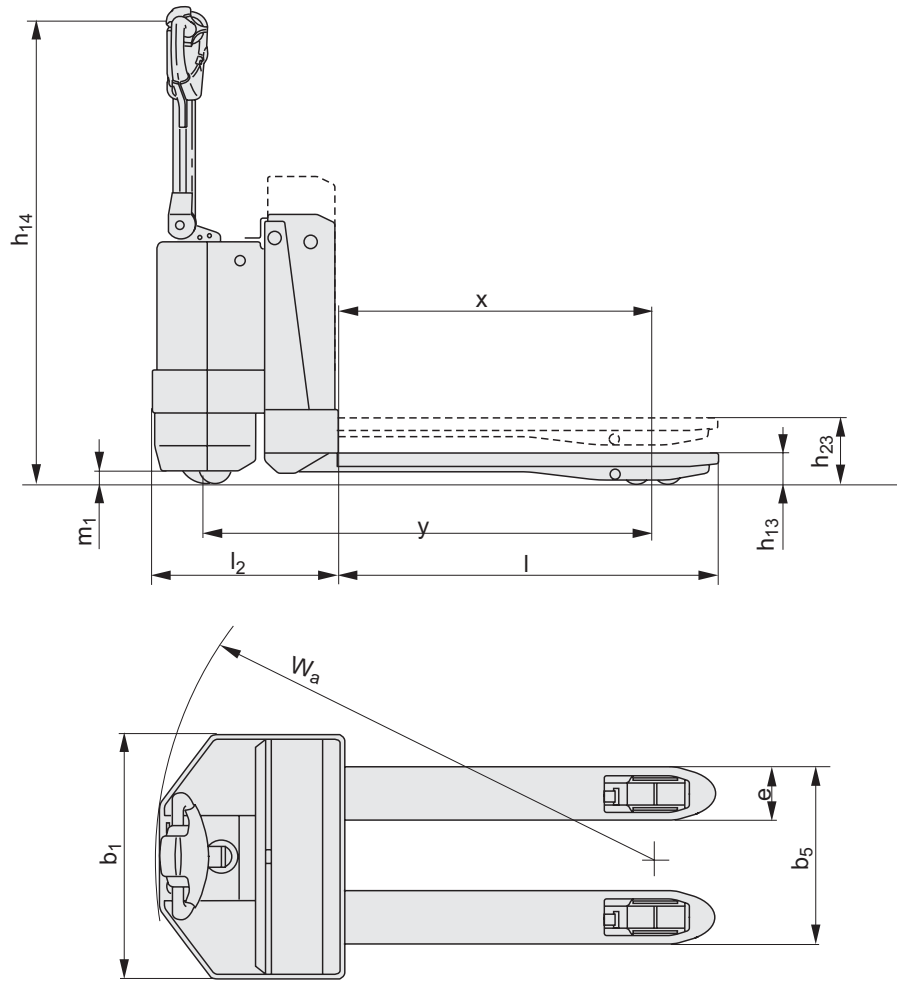

## ORION Range

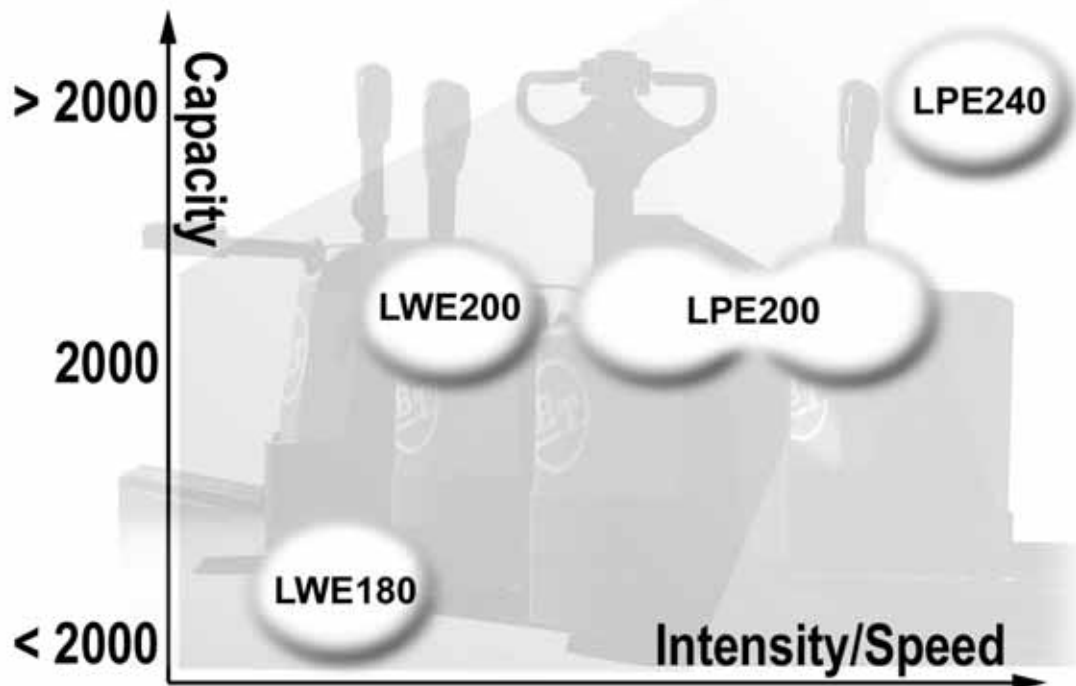



## Options

- **Load support**  
To provide additional safety for load and operator.
- **Built-in charger**  
The additional feature of a built-in charger placed in front of the electrical panel. Does not reduce the battery capacity.

- **Turtle button**  
Programmable function for reduced speed.
- **Writing table**  
For A4-size paper.
- **Cold store specification**  
For operation in temperatures down to -35° C.
- **Battery change device**  
For fast and easy battery exchange.



BT  
SE-595 81 Mjölby Sweden  
Tel: +46 (0)142 860 00  
Fax: +46 (0) 142 866 00  
Email: [info@bt-forklifts.com](mailto:info@bt-forklifts.com)  
[www.bt-forklifts.com](http://www.bt-forklifts.com)



*Handling innovation*