

D/G-SERIES

C4D250-350H

C4G250-350H



The C4D250-350E and C4G250-350H are powerful and reliable high performance counterbalance fork lift trucks. Featuring hydraulic hydrostatic transmission available in diesel and LPG versions. The LPG version is equipped with an extremely powerful engine, specifically developed for lift truck applications.



Technical Details		C4D250H/C4G250H	C4D300H/C4G300H	C4D350H/C4G350H
Power unit		diesel/LPG		
Operating type		driver seated		
Rated capacity	kg	2500	3000	3500
Load centre	mm	500	500	500
Load per axle without load, front/rear	kg	2070/1980	2100/2500	2260/2900
Load per axle with load, front/rear	kg	5920/630	6750/850	7790/870
Wheel type, front/rear ¹⁾		SE/PN/SE.TW/PN.TW	SE/PN/SE.TW/PN.TW	SE/PN/SE.TW/PN.TW
Number of wheels, front/rear		2-4/2	2-4/2	2-4/2
dimension, front		7,00-12 ^{3) 4)/7,00-12 ^{2) 7)}}	27x10-12 ^{3)/7,00-12 ^{2) 7)}}	27x10-12 ^{3)/7,00-12 ^{2) 7)}}
dimension, rear		6,50-10 ³⁾⁵⁾	6,50-10 ³⁾⁵⁾	23x9-10 ^{9)/6,50-10 ¹⁰⁾}
Centre of wheels, front	mm	1042/1042/1153/1205	1002/1038/1153/1205	1002/1038/1153/1205
Centre of wheels, rear	mm	1000	1000	1000
Fork arm carriage acc. to ISO-FEM		II A	III A	III A
Travel speed, without/with rated load	km/h	19/18,5	19/18,5	19/18,5
Service brake		hydraulic		
Parking brake		hand brake		
Lift speed, without/with rated load	m/s	0,51/0,49	0,51/0,47	0,50/0,45
Lowering speed, without/with rated load	m/s	< = 0,50	< = 0,50	< = 0,50
Nom. drawbar pull, without/with load	N	15000/19000	15000/19000	15000/19000
Gradient, without/with rated load	%	30/25	27/22	25/18
Weight, total	kg	4050	4600	5160
Engine: manufacturer, model		Kubota V3300/ Toyota 4Y		
Continuous power, C4D	kW/hp	46/63	46/63	46/63
Continuous power, C4G	kW/hp	37/50	37/50	37/50
Number of revolutions	1/min	2200/2400	2200/2400	2200/2400
No. of cylinders, displacement	cm ³	4-3300/4-2237	4-3300/4-2237	4-3300/4-2237
Model, gears		stepless hydrostatic	stepless hydrostatic	stepless hydrostatic
Clutch, type		—	—	—
Working pressure for attachments	bar	180	180	180

Dimensions, mm		C4D250H/C4G250H	C4D300H/C4G300H	C4D350H/C4G350H
x	Front axle to fork face	460 ⁸⁾	465 ⁸⁾	478 ⁸⁾
y	Wheel base	1750	1750	1820
α/β	Mast tilt forward/backward	5°/9°	5°/10°	5°/10°
h ₆	Height overhead guard	2180	2180	2180
h ₇	Height of driver's seat	1150	1150	1150
l ₂	Truck length incl. back of fork	2568 ⁸⁾	2697 ⁸⁾	2796 ⁸⁾
b ₁	Chassis, width	1215/1250 ^{4) 6)/} 1540/1642	1254/1313/ 1540/1642	1254/1313/ 1540/1642
s	Fork thickness	40	45	50
e	Fork width	120	120	150
l	Fork length	1000	1000	1000
m ₁	Floor clearance under mast	152	152	152
m ₂	Floor clearance mid wheelbase	170	170	170
A _{st}	Aisle width, mm Pallet size 800x1200/1000x1200 ¹¹⁾	4110/3911 ⁸⁾	4221/4022 ⁸⁾	4435/4305 ⁸⁾
W _a	Turning radius	2250	2356	2510

- 1) SE = Superelastic, PN = Pneumatic, TW = Twin
- 2) SE.TW
- 3) SE-PN
- 4) 27x10-12 SE-PN (Optional)
- 5) 23x9-10 SE (Optional)
- 6) PN = 1313, SE = 1254
- 7) PN.TW
- 8) With sideshift = +25mm
- 9) SE
- 10) PN (Optional)
- 11) Shortside handling / longside handling

Truck performance and dimensions are nominal and subject to tolerances.
BT Products AB products and specifications are subject to change without notice.
All data is based on VDI 2198.

D/G-SERIES

Mast, mm	Duplex				Duplex FFL		Triplex				Triplex FFL				
h_3 Lift height	3160	3660	4160	4960	2930	3160	4305	4965	5565	6765	4310	4460	4960	5560	6060
C4D/G250H															
h_1 Height of mast, min.	2252	2502	2752	3202	2132	2252	2132	2352	2552	3052	2132	2182	2352	2552	2752
h_2 Free lift	100	100	100	100	1437	1577	45	45	45	45	1437	1487	1657	1857	2057
h_4 Height of mast, max.	3805	4305	4805	5632	3625	3855	4972	5632	6232	7532	5005	5155	5655	6255	6755
C4D/G300-350H															
h_1 Height of mast, min.	2252	2502	2752	3202	2132	2252	2132	2352	2552	3052	2132	2182	2352	2552	2752
h_2 Free lift	100	100	100	100	1436	1556	45	45	45	45	1436	1486	1656	1856	2056
h_4 Height of mast, max.	3833	4333	4833	5633	3626	3856	4978	5638	6238	7532	5006	5156	5656	6256	6756

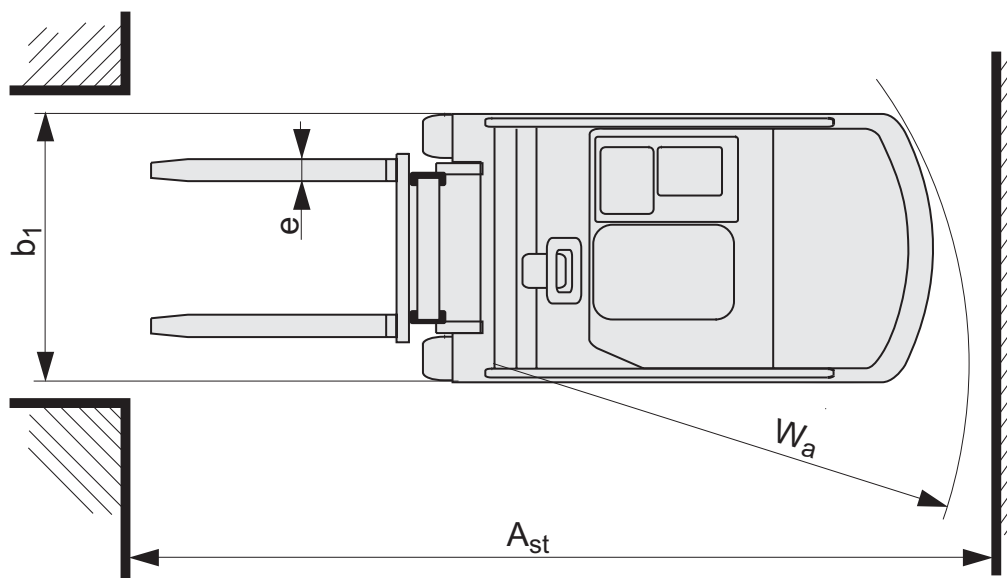
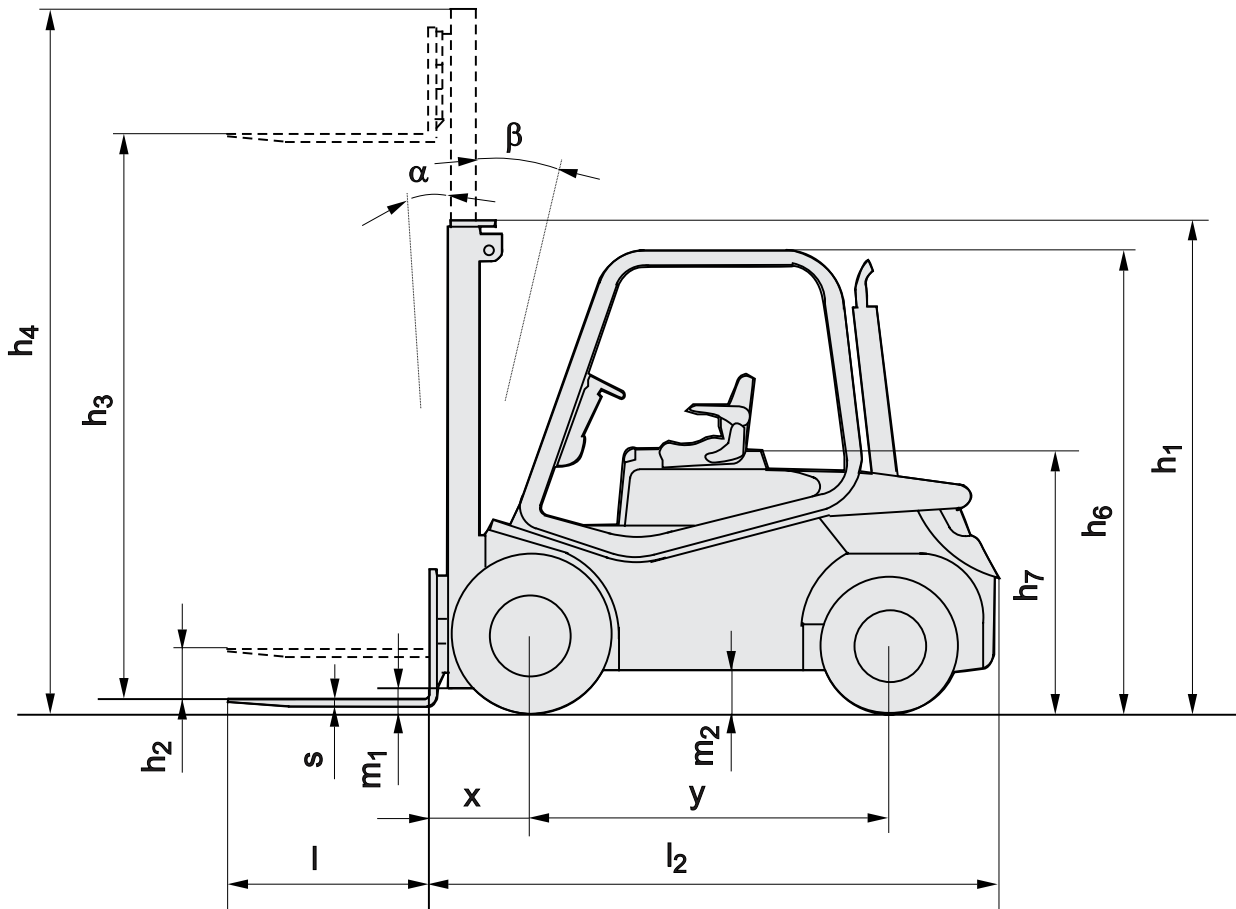

D/G-SERIES



- High visibility and stability. The position of the uprights, which are widely spaced, guarantees excellent visibility and at the same time gives a rigid structure even at great height. Equipped with side shift as standard.
- Fully adjustable steering wheel. Designed to create the ideal driving position.
- Ergonomically designed controls. The rotating-switch controlled parking brake is within easy reach of the driver.
- The hydrostatic transmission can be manually customized to set the parameters of the acceleration, deceleration, change of direction, brake release and inching control to suit every operation's requirements perfectly.
- The front wheels — which are among the largest in this class of trucks — give load stability, operator comfort and easy manoeuvring even on uneven ground.
- The steering axle, mounted on anti-vibration material, has an enhanced manoeuvrability thanks to a compact design. This feature protects the truck against the type of accidental damage typically associated with outdoor usage.
- Reduced maintenance for the no-wear-oil-bath brakes. Maximum reliability — whenever the accelerator pedal is released and the truck is stationary the negative brake application holds the truck in position, whether on level ground or on ramps.

Truck features	C4D/G250H	C4D/G300H	C4D/G350H
Hydrostatic transmission	S	S	S
Tilting mast	S	S	S
Independent hydrostatic drive wheel motors	S	S	S
Diesel engine	S	S	S
LPG Engine	S	S	S
Controls and instruments			
Hydraulic programmable hydrostatic control	S	S	S
Hour meter	S	S	S
Hydraulic steering	S	S	S
Side-shift	S	S	S
Balanced pedals control	O	O	O
Safety features			
Clear-view mast	S	S	S
Clear-view overhead guard	S	S	S
Driver detection system	S	S	S
Hydrostatic brakes	S	S	S
Hydraulic parking brake	S	S	S
Drivers compartment features			
Adjustable seat with safety belt	S	S	S
Adjustable steering wheel	S	S	S
Enclosed cab with or without heating	O	O	O
Maintenance features			
Easy access for maintenance	S	S	S
Fault diagnosis facility	S	S	S
Oil bath brakes	S	S	S

S = Standard feature

O = Optional feature

— = Not available