

C4E120-200
C4E160L-180L



This Cargo AC electric counterbalance truck from BT has the classic 4-wheel configuration designed for good general purpose work. With its low centre of gravity, the very stable design utilises two independent high power front wheel traction AC motors to form an electronic differential which allows it to work in the tightest of spaces.



Technical Details		120	150	160	180	160L	180L	200
Power unit		electric						
Operating type		driver seated						
Rated capacity	kg	1200	1500	1600	1800	1600	1800	2000
Load centre	mm	500	500	500	500	500	500	500
Load per axle without load, front/rear	kg	1665/1285	1670/1470	1650/1530	1630/1690	1820/1480	1830/1550	1820/1700
Load per axle with load, front/rear	kg	3675/475	4150/490	4300/480	4600/520	4330/570	4650/530	4940/580
Number of wheels, front/rear		2/2	2/2	2/2	2/2	2/2	2/2	2/2
Wheel type, front/rear ¹⁾		C/SE/PN	C/SE/PN	C/SE/PN	C/SE	C/SE/PN	C/SE	C/SE
dimension, front		432x152/ 18x7-8/ 18x7-8	432x152/ 18x7-8/ 18x7-8	432x152/ 18x7-8/ 18x7-8	457x178/ 200 50-10	432x152/ 18x7-8/ 18x7-8	457x178/ 200 50-10	457x178/ 200 50-10
dimension, rear		381x127/ 16x6-8/ 16x6-8	381x127/ 16x6-8/ 16x6-8	381x127/ 16x6-8/ 16x6-8	381x127/ 16x6-8	381x127/ 16x6-8/ 16x6-8	381x127/ 16x6-8	381x127/ 16x6-8
Centre of wheels, front	mm	839/851/ 851	839/851/ 851	839/851/ 851	828/861	839/851/ 851	828/861	828/861
Centre of wheels, rear	mm	863/843/ 843	863/843/ 843	863/843/ 843	863/843	863/843/ 843	863/843	863/843
Fork arm carriage acc. to ISO-FEM		II A	II A	II A	II A	II A	II A	II A
Travel speed, without/with rated load	km/h	14.5/14.5	14.5/14.5	14.5/14.5	14.5/14.5	14.5/14.5	14.5/14.5	14.5/14.5
Service brake		hydraulic	hydraulic	hydraulic	hydraulic	hydraulic	hydraulic	hydraulic
Parking brake		hand brake	hand brake	hand brake	hand brake	hand brake	hand brake	hand brake
Lift speed, without/with rated load	m/s	0,54/0,35	0,54/0,34	0,54/0,34	0,54/0,33	0,54/0,34	0,54/0,33	0,54/0,32
Lowering speed, without/with rated load	m/s	0,50/0,55	0,50/0,55	0,50/0,55	0,50/0,55	0,50/0,55	0,50/0,55	0,50/0,55
Nom. draw-bar pull, without/with load	N	3140/2900	3140/2840	3140/2820	3140/2780	3140/2820	3140/2780	3140/2740
Max. draw-bar pull, without/with load (S2 5')	N	9000/8760	9000/8700	9000/8680	9000/8640	9000/8680	9000/8640	9000/8620
Gradient, without/with rated load (S2 30')	%	11,7/7,7	10,8/6,6	10,7/6,4	10,0/5,8	10,2/6,2	9,7/5,7	9,4/5,2
Max. gradient, without/with rated load (S2 5')	%	30,0/21,0	28,0/18,0	28,0/17,5	26,5/16,0	27,0/17,0	26,0/16,0	25,0/15,0
Drive motor	kW	4,5 x 2	4,5 x 2	4,5 x 2	4,5 x 2	4,5 x 2	4,5 x 2	4,5 x 2
Lift motor	kW	10	10	10	10	10	10	10
Battery capacity	V/Ah	48/420-500	48/420-500	48/525-625	48/525-625	48/630-750	48/630-750	48/630-750
Battery weight	kg	775	775	920	920	1090	1090	1090
Weight with battery	kg	2950	3140	3180	3320	3300	3380	3520
Steering system		hydraulic	hydraulic	hydraulic	hydraulic	hydraulic	hydraulic	hydraulic
Speed control		AC Mosfet	AC Mosfet	AC Mosfet	AC Mosfet	AC Mosfet	AC Mosfet	AC Mosfet
Working pressure for attachments	bar	140	140	140	140	140	140	140

Dimensions, mm		120	150	160	180	160L	180L	200
x	Front axle to fork face	365,5 ²⁾	365,5 ²⁾	365,5 ²⁾	365,5 ²⁾	365,5 ²⁾	365,5 ²⁾	365,5 ²⁾
y	Wheel base	1290	1290	1400	1400	1532	1532	1532
α/β	Mast tilt forward/backward	2°30'/6°	2°30'/6°	2°30'/6°	2°30'/6°	2°30'/6°	2°30'/6°	2°30'/6°
h ₆	Height overhead guard	1950	1950	1950	1950	1950	1950	1950
h ₇	Height of driver's seat	888	888	888	888	888	888	888
l ₂	Truck length incl. back of fork	1949 ²⁾	1994 ²⁾	2059 ²⁾	2104 ²⁾	2191 ²⁾	2191 ²⁾	2236 ²⁾
b ₁	Chassis, width	990/1003	990/1003	990/1003	1006/1066	990/1003	1006/1066	1006/1066
s	Fork thickness	35	35	35	35	35	35	35
e	Fork width	100	100	100	130	100	130	130
l	Fork length	1000	1000	1000	1000	1000	1000	1000
m ₁	Floor clearance under mast	100	100	100	100	100	100	100
m ₂	Floor clearance mid wheelbase	90	90	90	90	90	90	90
A _{st}	Aisle width, mm	3496/ 3301 ²⁾	3536/ 3341 ²⁾	3599/ 3403 ²⁾	3638/ 3442 ²⁾	3721/ 3524 ²⁾	3721/ 3524 ²⁾	3761/ 3564 ²⁾
W _a	Turning radius	1730	1770	1833	1872	1955	1955	1995

1) C = Cushion, SE = Superelastic, PN = Pneumatic, TW = Twin

2) With side shift = +34mm

3) Shortside handling / longside handling

Mast, mm																		
h_3	Lift height	2840	2970	3170	3670	4170	4270	4320	4470	4670	4965	4970	5565	5570	6165	6170	6570	6970
Duplex																		
h_1	Height of mast, min.		2060	2160	2410	2660				2910								
h_2	Free lift		80	80	80	80				80								
h_4	Height of mast, max.		3520	3720	4220	4720				5220								
Duplex FFL																		
h_1	Height of mast, min.	1990		2160	2410	2660												
h_2	Free lift	1410		1580	1830	2080												
h_4	Height of mast, max.	3420		3750	4250	4750												
Triplex																		
h_1	Height of mast, min.							2010			2260		2460		2710		2860	
h_2	Free lift							0			0		0		0		0	
h_4	Height of mast, max.							4900			5570		6170		6820		7240	
Triplex FFL																		
h_1	Height of mast, min.						1990		2060			2260		2460		2710	2860	3010
h_2	Free lift						1410		1480			1680		1880		2130	2280	2430
h_4	Height of mast, max.						4850		5050			5550		6150		6750	7150	7550

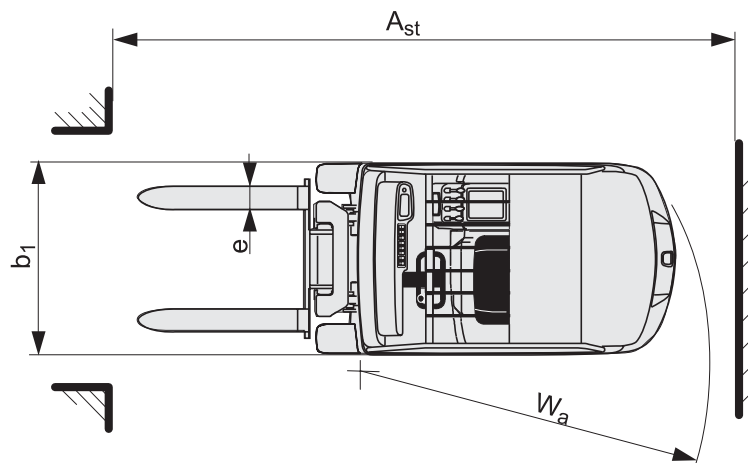
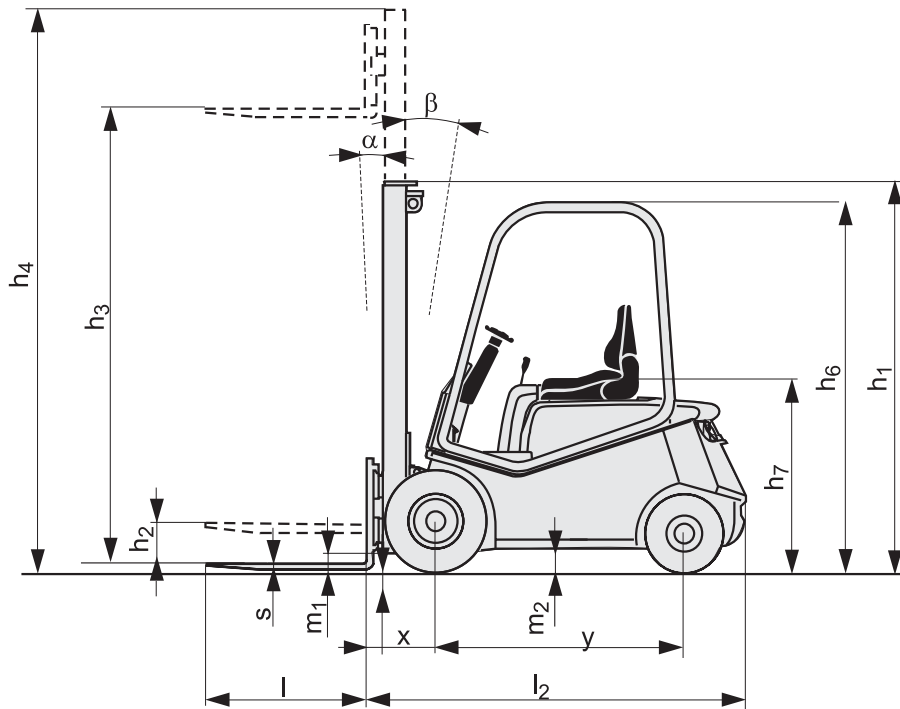

Truck performance and dimensions are nominal and subject to tolerances.
 BT Products AB products and specifications are subject to change without notice.
 All data is based on VDI 2198.



- The ergonomic cab features the highest standards in operator comfort, safety and ease of access.
- High visibility and stability. The position of the uprights, which are widely spaced, guarantees excellent visibility and at the same time gives a rigid structure even at great height. Equipped with integrated side-shift as standard.
- Various drive programs can be selected by simply pressing the push-buttons on the steering column.
- The automobile-style dashboard has main function indicator lights plus error codes display for a rapid fault identification.
- The AC controller can be used to program and customize the parameters of the various functions; braking, traction and lift acceleration, and minimum acceleration threshold.
- The CAN-Bus simplifies the electrical system by reducing wiring and increases the flexibility of the truck control system.
- As well as guaranteeing constantly effective braking action, the use of oil bath brakes allows savings on routine servicing costs.

Truck features	C4E120-200	C4E160L-180L
Adjustable fork width	S	S
Tilting mast	S	S
Counter-rotating front wheels	S	S
High capacity battery models	—	S
Controls and instruments		
Hydraulic steering	S	S
Information display	S	S
Sideshift	S	S
Electronic fingertip controls	O	O
Mini-joystick electronic controls	O	O
Driving features		
Electronic regenerative brakes	S	S
Three driving programs	S	S
Curve cut-back speed	S	S
Safety features		
Clear-view mast	S	S
Emergency cut-off	S	S
Programmable performance	S	S
Drivers compartment features		
Adjustable steering wheel	S	S
Enclosed cab with or without heating	O	O
Maintenance features		
Easy access for maintenance	S	S
Fault diagnosis facility	S	S
Oil bath brakes	S	S
Battery management features		
Battery status indicator	S	S
Battery discharge prevention system	S	S
Special applications		
Coldstore version	O	O
EEx version (ATEX)	O	O

S = Standard feature

O = Optional feature

— = Not available

BT
 SE-595 81 Mjölby Sweden
 Tel: +46 (0)142 860 00
 Fax: +46 (0) 142 866 00
 Email: info@bt-forklifts.com
 www.bt-forklifts.com

