

Lifter with scale

LHM200SC
LHM200SCQ



The BT Lifter with scale combines the controlling function of a very accurate weighing system with the mobility and the flexible availability of a hand pallet truck. You weigh pallets and containers during transport, at the place of the handling. You save time when checking incoming and outgoing goods and during dosing and filling processes.



Technical Details		LHM200SC	LHM200SCQ
Rated capacity	kg	2000	2000
Weight	kg	105	105
Steering wheel	mm	Ø 175x60	Ø 175x60
Fork wheels, single/bogie	mm	Ø 85x100/Ø 85x75	Ø 85x100/Ø 85x75
Pump force, rated capacity	kg	31	31
Pulling force		17	17

Dimensions, mm		LHM200SC	LHM200SCQ
x	Front axle to fork face	970	970
y	Wheel base	1220	1220
h ₁₃	Height of lowered fork	90	90
h ₃	Lift height	205	205
h ₁₄	Height of handle in neutral pos.	1220	1220
l ₂	Truck length incl. back of fork	370	370
b ₁	Chassis, width	520/685	520/685
s	Fork thickness	65	65
e	Fork width	170	170
l	Fork length	1150	1150
b ₅	Width across fork	540/700	540/700
m ₂	Floor clearance mid wheelbase	25	25
A _{st}	Aisle width, min (Pallet 800x1200 mm)	1770	1770
W _a	Turning radius	1405	1405

1) With rated capacity on a smooth, dry level concrete floor

Datas are based on l = 1150mm, nylon wheels

Specifications	
<ul style="list-style-type: none"> ● Graduation multi-range: 0 — 200 kg: graduation 0,2kg. 200 — 500 kg: graduation 0,5 kg. 500 — 2000 kg: graduation 1,0 kg. ● Maximum inaccuracy: 0,1% of the applied weight. ● Protection class: Load cells, cabling IP67 and indicator IP65. 	<ul style="list-style-type: none"> ● Battery life: up to 35 hours, low voltage indication 5 hours before switch off. ● Battery: 12 Vdc/ 1.2 Ah, exchangeable. ● Charger: 230 Volt / 12 Vdc - 300 mA.
Functions	
<ul style="list-style-type: none"> ● Automatic and manual zero correction. ● Gross /net weighing. ● Automatic and manual tare. 	<ul style="list-style-type: none"> ● Cumulative totaling, with sequence number. ● Error message in display. ● Automatic switch off after 30minutes of non-use (programmable).

Variants	
Legal for Trade	Quick Lifter
<p>Used for:</p> <ul style="list-style-type: none"> ● Determining the load for trade transactions. ● Determining the load for calculation of claim, legal charge, tax, premium, fine, reimbursement or other similar fees. ● Determining of a price based on the load for direct sale to the public or for pre-packed articles. 	<ul style="list-style-type: none"> ● For customer applications calling for high volumes of pallet movements every day. ● The forks reach the pallet with the first pump stroke and lift the pallet with the second. ● Data: see LHM200SCQ above.

Lifter with scale

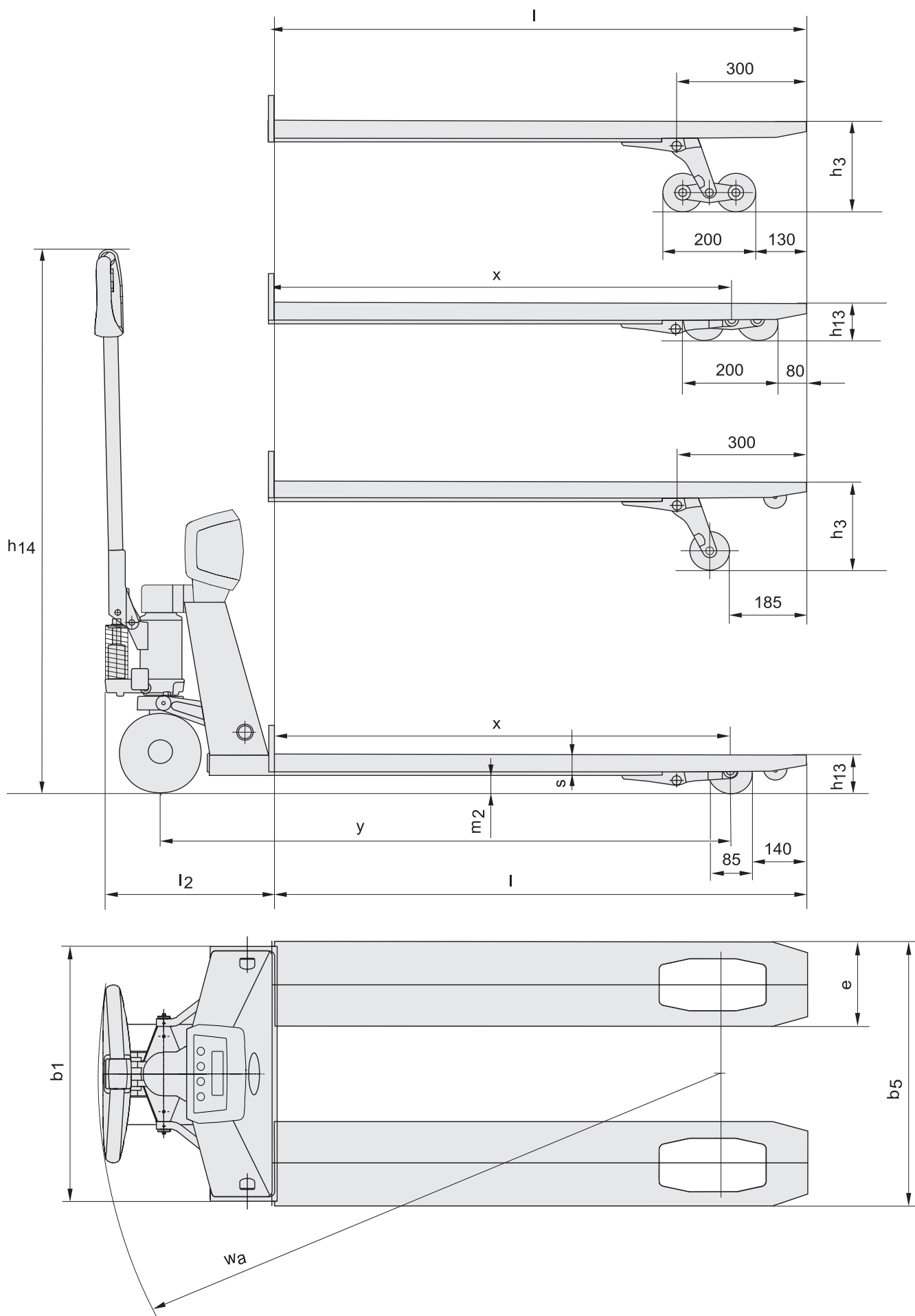

Truck performance and dimensions are nominal and subject to tolerances.
BT Products AB products and specifications are subject to change without notice.
All data is based on VDI 2198



- The BT Lifter with scale is developed for industrial applications and is protected against water, dust and shocks.
- The exchangeable battery module provides for 35 hours of use, and makes it possible to use the hand pallet truck without weighing when charging the battery.
- Legal for trade version, can be provided.
- Built in printer for printing weight data on site, is available as an option.
- Extra battery for continuous use can be purchased.
- Load cells, cabling IP67 and indicator IP65 protection.
- Customized configurations and designs can be available on request.
- A large variety of wheel types: nylon, polyurethane, powerthane and rubber.
- 10/12 greasable bushings ensure a long service life.
- Angled highstrength polymer handle for best ergonomic grip.
- LHM200SC has been environmentally declared. Separate information sheet is available.



Truck features	LHM200SC	LHM200SCQ
Choice of chassis widths	S	S
Choice of fork lengths	—	—
Choice of wheel types	O	O
Climber wheels	S	S
Bogie fork wheels	O	O
Controls and instruments		
Tiller arm steering	S	S
Driving features		
180° steering	S	S
Safety features		
Handbrake	—	—
Parking brake	O	O
Maintenance features		
Lubrication points	S	S
Special applications		
Coldstore version	—	—

S = Standard feature

O = Optional feature

— = Not available