



The Pro Lifter M LHT100 from BT is a unique combination of the market leading Hand Pallet truck Lifter LHM230, with the added feature of a motorised drive function. You will get the same high quality level that you recognise from the LHM230. It is easy to maneuver and has the compact size of a hand pallet truck which makes it well suited for small spaces.



Technical Details		LHT100
Power unit		Battery
Rated capacity	kg	1000
Weight without battery	kg	89
Drive wheel	mm	Ø 175x50
Fork wheels, single/bogie	mm	Ø 85x100 / Ø 85x75
Pump force, rated capacity	kg	19
Travel speed, without/with rated load	km/h	5,0/3,5
Drive motor	kW	0,2

Dimensions, mm		LHT100
x	Front axle to fork face	985
y	Wheel base	1230
h ₃	Lift height	200
h ₁₄	Height of handle in neutral pos.	1220
h ₁₃	Height of lowered fork	85
l ₂	Truck length incl. back of fork	410
b ₁	Chassis, width	520 / 685
s	Fork thickness	45
e	Fork width	156
l	Fork length	800 / 910 / 1000 / 1070 / 1150 / 1220
b ₅	Width across fork	520 / 685
m ₂	Floor clearance mid wheelbase	40
A _{st}	Aisle width, min (Pallet 800x1200 mm)	1810
W _a	Turning radius	1395

Datas are based on l = 1150mm, nylon wheels

Battery and charger		LHT100
Battery capacity	Ah	24
Battery	V	2 x 12
Battery weight	kg	2 x 9,15
Battery charger	A	3

Pro Lifter M

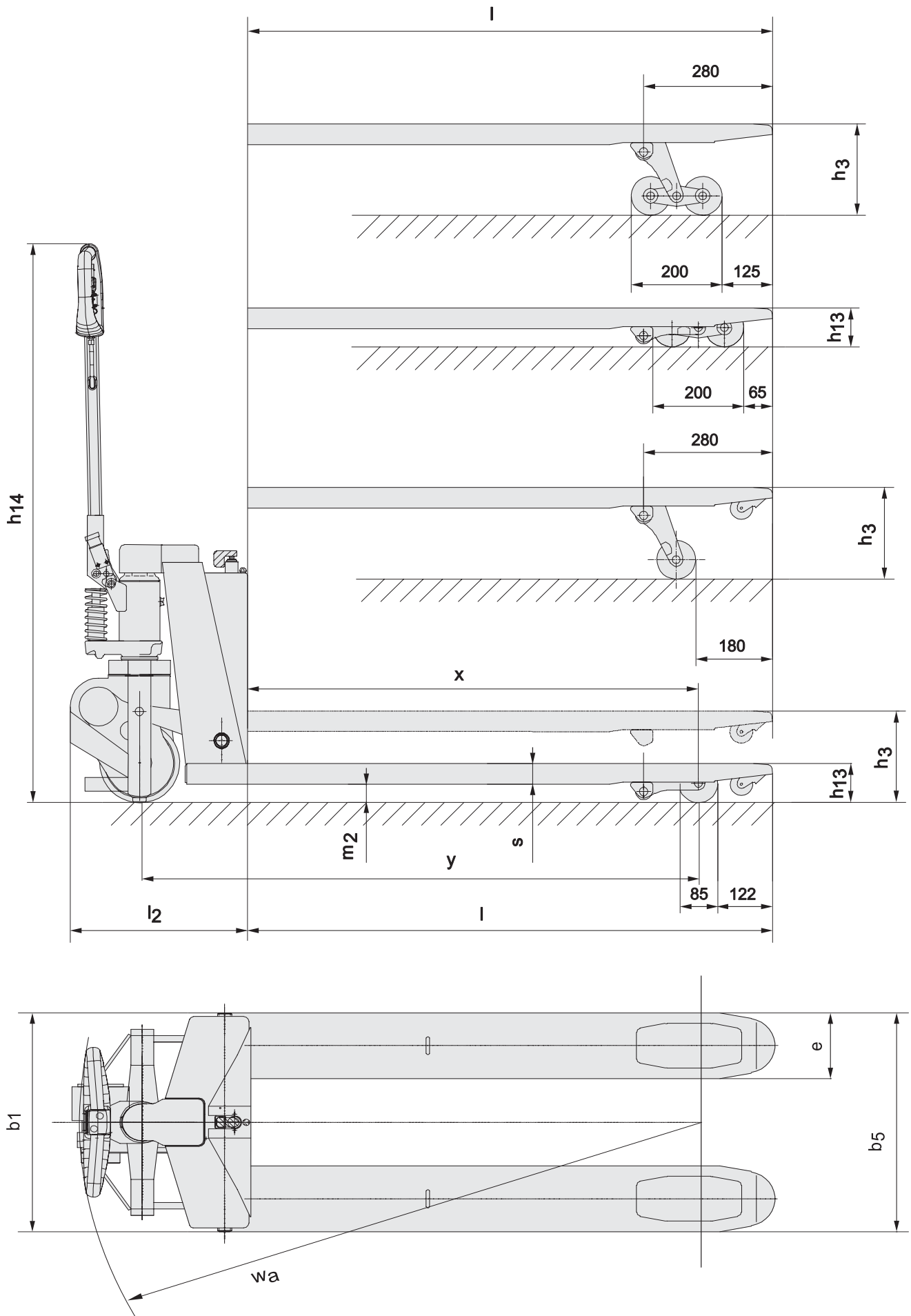



- The Pro Lifter M LHT100 will eliminate the strain from pulling and pushing a Hand Truck . This 1000 kg capacity machine is another step towards an ergonomic workplace.
- The safety features include emergency stop key, safety switch against collision, and tow bar switch for the two extreme positions of the tow bar.
- Suitable for indoor applications such as stores, back of store, supermarkets, light industry, hospitals, pharmacies, libraries etc
- Increased ergonomomy, no strain on arms, shoulder and back
- Increases productivity
- Easily operated
- Two direction buttons
- Two speeds. Double-click for higher speed.
- Built-in charger with a separate charging cable.
- Also available in U-model with minimum height 75 mm.
- This product has been environmentally declared. Separate information sheet is available.

Truck features	LHT100
Choice of chassis widths	S
Choice of wheel types	O
Climber wheels	S
Bogie fork wheels	O
Controls and instruments	
Fingertip controls	S
Tiller arm steering	S
Driving features	
180° steering	S
Electronic braking system	S
Electronic speed control	S
Safety features	
Automatic parking brake	S
Emergency cut-off	S
Maintenance features	
Lubrication points	S
Battery management features	
Battery status indicator	S
Built-in charger	S

S = Standard feature

O = Optional feature

— = Not available