

LHM230P
LHM230QP



To get a hand pallet truck moving is the heaviest part of the transport. With BT Pro Lifter the truck will take the first steps by itself. A hand pallet truck loaded with 2300 kg needs a starting force of 45 kg to get into motion. With BT Pro Lifter that amount is reduced to 15 kg.



Technical Details		LHM230P	LHM230QP
Rated capacity	kg	2300	2300
Weight	kg	77	77
Steering wheel	mm	Ø 175x60	Ø 175x60
Fork wheels, single/bogie	mm	Ø 85x100/ Ø 85x75	Ø 85x100/ Ø 85x75
Pump force, rated capacity	kg	34	34
Pulling force		22 ¹⁾	22 ¹⁾

Dimensions, mm		LHM230P	LHM230QP
x	Front axle to fork face	985	985
y	Wheel base	1217	1217
h ₃	Lift height	200	200
h ₁₄	Height of handle in neutral pos.	1220	1220
h ₁₃	Height of lowered fork	85	85
l ₂	Truck length incl. back of fork	425	425
b ₁	Chassis, width	520/685 ²⁾	520/685 ²⁾
s	Fork thickness	45	45
e	Fork width	156	156
l	Fork length	800/910/1000/1070/ 1150/1220 ²⁾	800/910/1000/1070/ 1150/1220 ²⁾
b ₅	Width across fork	520/685 ²⁾	520/685 ²⁾
m ₂	Floor clearance mid wheelbase	40	40
A _{st}	Aisle width, min (Pallet 800x1200 mm)	1825	1825
W _a	Turning radius	1410	1410

- 1) With rated capacity on a smooth, dry level concrete floor
2) Other fork lengths and widths on request

Datas are based on l = 1150mm, powerthane wheels

BT PRO LIFTER

with 2300 kg load

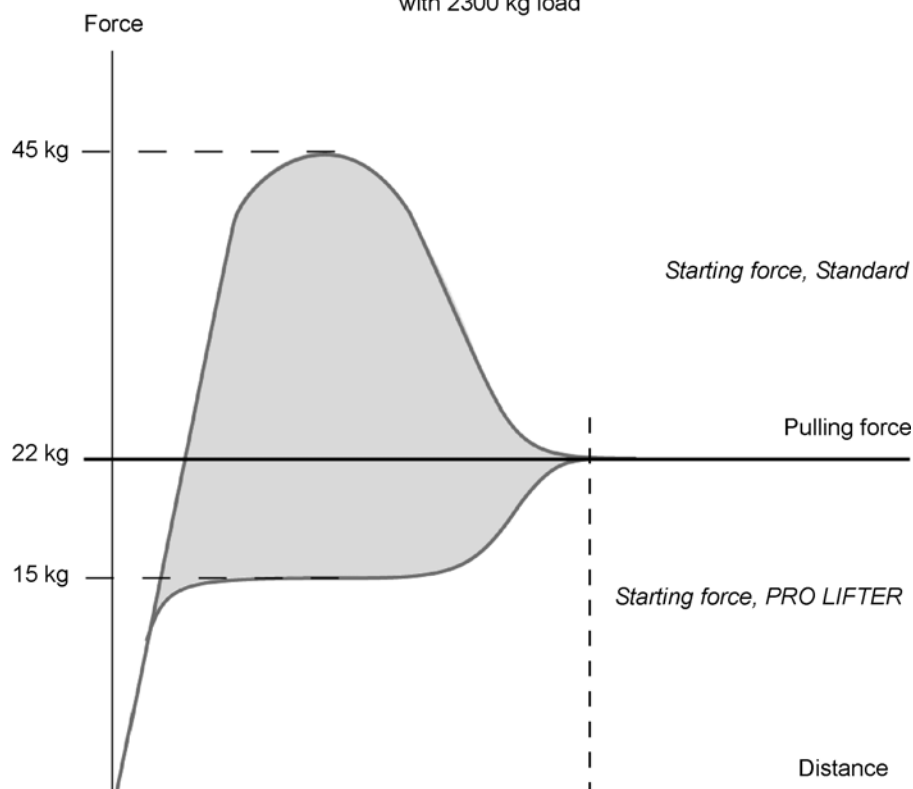

One third of the wheels periphery

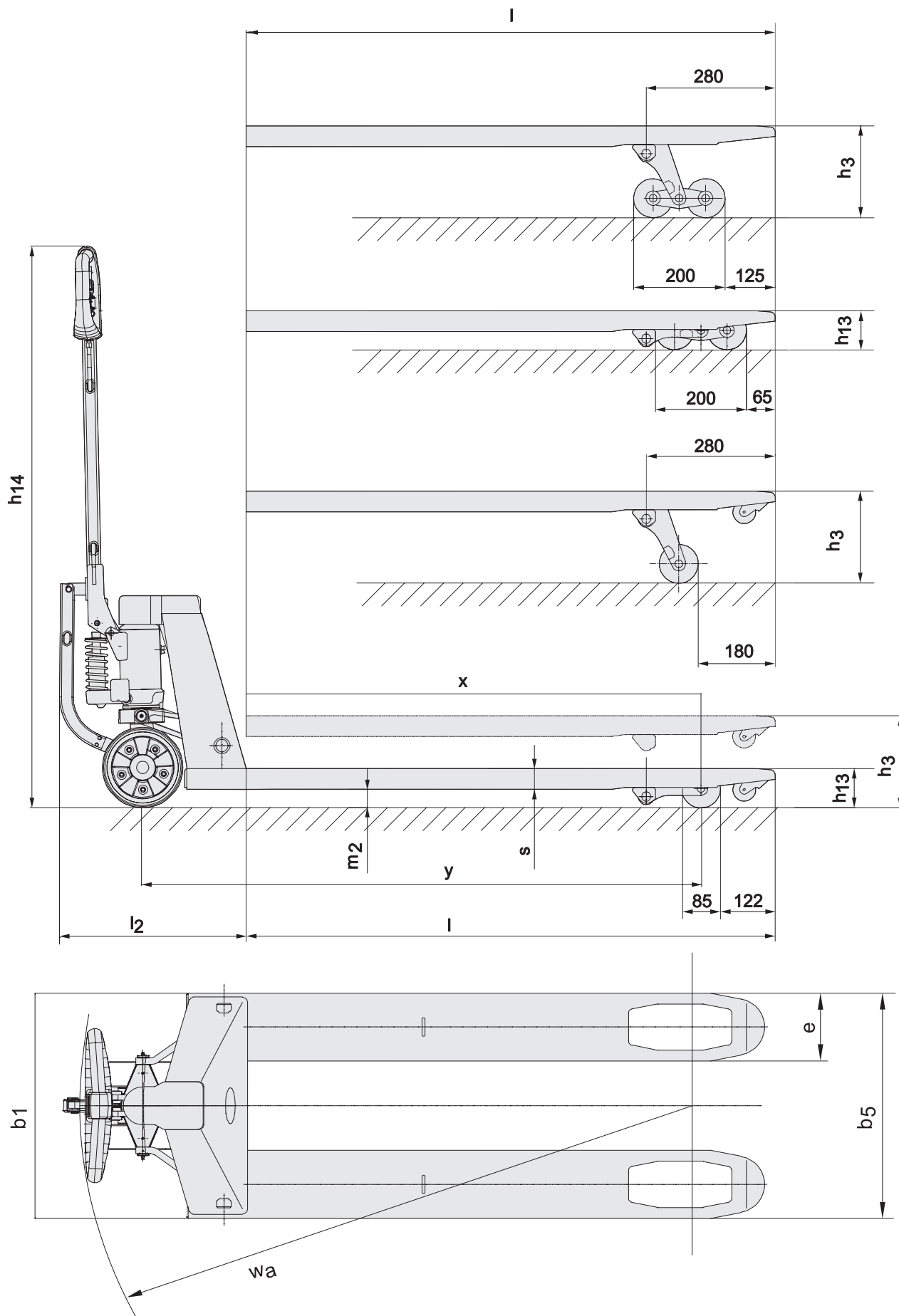

Truck performance and dimensions are nominal and subject to tolerances.
 BT Products AB products and specifications are subject to change without notice.
 All data is based on VDI 2198



- A connection between the tow bar and the steering wheels transfer the force from the pump stroke to the wheel to get the truck started.
- Through a control on the handle you can choose the direction of the starting force.
- Unique option for heavy duty applications and easy positioning.
- Smooth driving over uneven surfaces and thresholds.
- High ergonomomy. Reduces strain to arms, shoulders and back.
- Increases the productivity.
- Steering wheel in powerthane is standard.
- The Quick Lift is the best ergonomic choice, because the number of pump strokes are reduced.
- Also available in U-model with minimum height 75 mm.
- BTs unique lifetime guarantee, gives the customer 99-years functional guarantee on the fork frame. The guarantee on the pump unit and the tow bar is five years.
- This product has been environmentally declared. Separate information sheet is available.



Truck features	LHM230P	LHM230QP
Choice of chassis widths	S	S
Choice of fork lengths	S	S
Choice of wheel types	O	O
Climber wheels	S	S
Bogie fork wheels	O	O
Controls and instruments		
Tiller arm steering	S	S
Driving features		
180° steering	S	S
Safety features		
Handbrake	—	—
Parking brake	—	—
Load support	O	O
Maintenance features		
Lubrication points	S	S
Special applications		
Coldstore version	—	—

S = Standard feature

O = Optional feature

— = Not available

